

REV	ECN #	DESCRIPTION	DRAWING	APPROVED	DATE
A		NEW RELEASE	DEY1		04/26/12

Specification
 *Electrical Characteristics:
 Contact Current Rating:0.5 Amperes.
 Dielectric Withstanding Voltage:AC500V r.m.s.
 Insulation Resistance:500 MΩ Minimum.
 Contact Resistance: 30 mΩ Maximum.
 *Environmental:
 Operating Temperature: - 55C~+ 85C.
 *Environmental:
 Mating Cycles: 5,000 Insertions.
 *Material:
 Insulator:HI-Temp Plastic UL 94V-0 Rated.
 Contact:Copper Alloy(t=0.15mm).
 Shell:Copper Alloy(t=0.20mm).

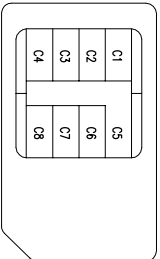

- 料号编码
SM24-06 A B 05-02
 ① 产品系列: SM24:SIM卡连接器
 ② 产品PIN数: 06: 6PIN
 ③ 塑胶材料: A: LCP
 ④ 塑胶颜色: B: 黑色
 ⑤ 产品流水号 02: SIM CARD 2.8H 抽屉式 垫高型

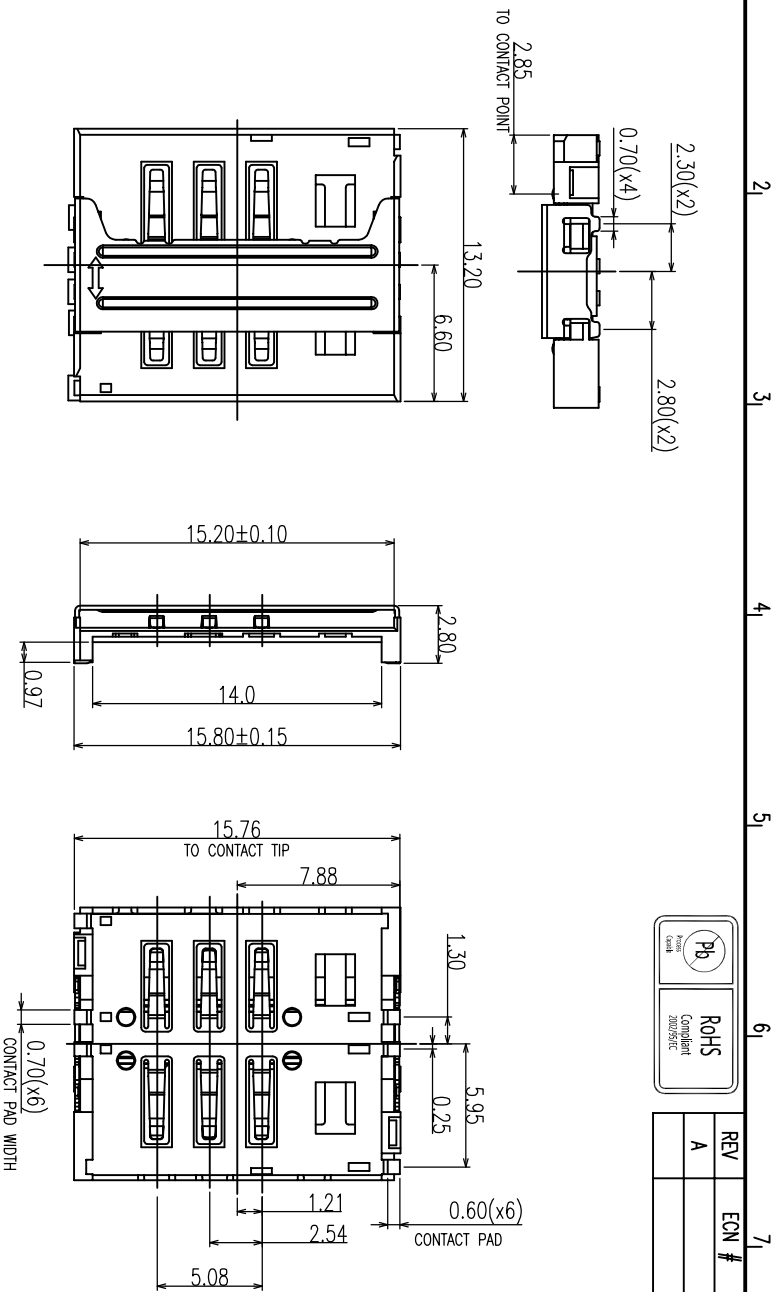
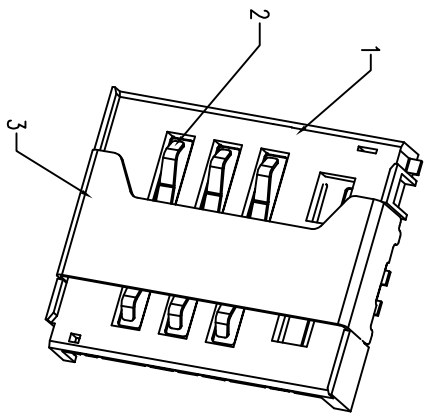
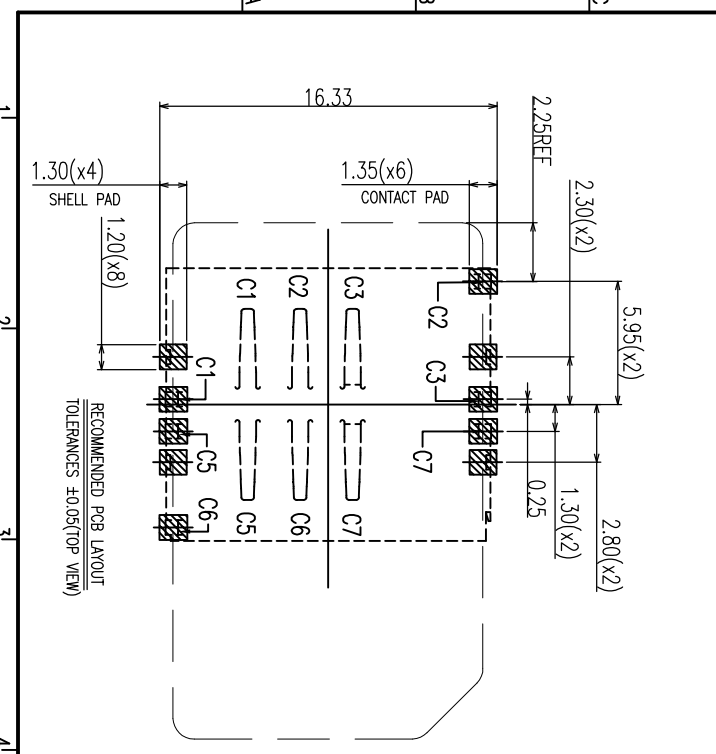

CUSTOMER DRAWING		YTCOON http://www.ytconn.com		Dongguan YTCOON Electronics Technology Co., Ltd.	
GENERAL TOLERANCE	X ±0.20 XX ±0.15 XXX ±0.10	DRAWING	DEY1	TITLE	SIM CARD 2.8H 抽屉式 垫高型
ANGLE TOLERANCE	X ±3° XX ±2° XXX ±1°	APPROVED		P/N:	SM24-06AB05-02
		DATE	2012.04.26	DRAWING NO.	C-SM24-02
		UNIT	mm	SCALE	1:1
		SIZE	A4	SHEET	1 of 1
		REV	A		