

| REV | ECH # | DESCRIPTION | DRAWING | APPROVED | DATE       |
|-----|-------|-------------|---------|----------|------------|
| A   |       | NEW RELEASE | DEV1    |          | 2012/09/28 |
|     |       |             |         |          |            |

NOTES:

- 1) MATERIAL:  
HOUSING: THERMOPLASTIC, UL 94V-0, COLOR: BLACK  
CONTACT: COPPER ALLOY
- 2) FINISH  
CONTACT: GOLD FLASH
- 3) PRODUCT SPECIFICATIONS:  
3-1 WITHSTANDING: 500V AC / MINUTE  
3-2 CONTACT RESISTANCE: 30 milliohm (INITIAL) Max.  
3-3 INSULATION RESISTANCE: 100MEGohm Min  
3-4 INSERTION FORCE: 2.22kg Max (INITIAL)  
3-5 WITHDRAWAL FORCE: 0.22kg Min (INITIAL)  
3-6 DURABILITY: 5000 CYCLES

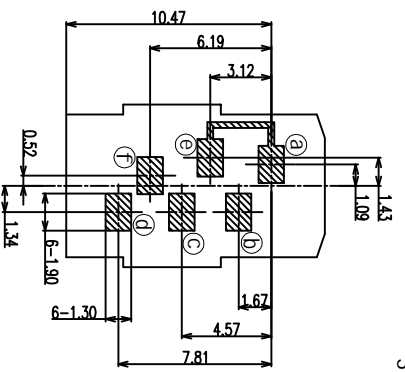
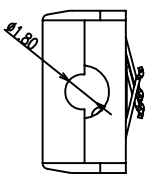
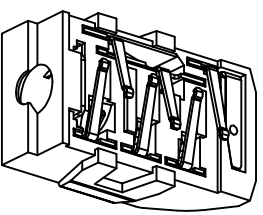
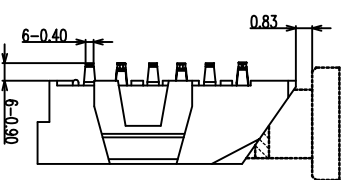
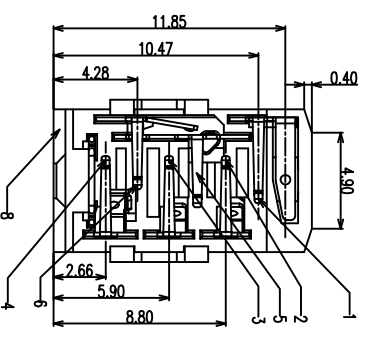
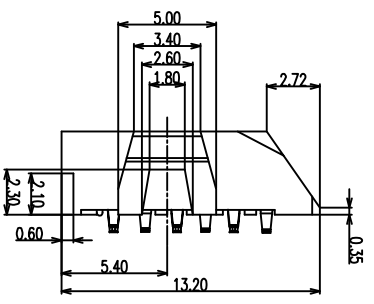
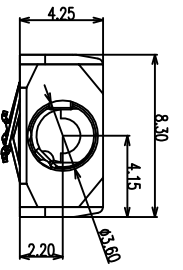

PCB LAYOUT TOP VIEW  
TOLERANCE: ±0.05

- PJ15-06 A B 07-00
- ① PRODUCT SERIES: PJ15: PHONE JACK CONNECTOR 压接式
- ② PIN NO.: 06: 6PIN
- ③ MATERIAL: A: PA9T
- ④ SERIES NO.: 00: 4.25H, 标准型

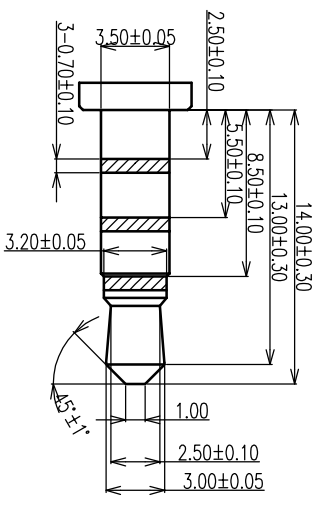

PLUG SPEC

| plug band | layout NO | contact NO |
|-----------|-----------|------------|
| R         | ①         | ⑥          |
| M         | ②         | ⑤          |
| P         | ③         | ④          |
| O         | ④         | ③          |
| R         | ⑤         | ②          |

Circuit diagram

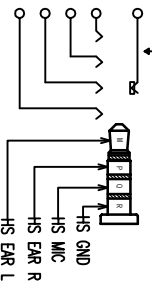

**CUSTOMER DRAWING**

**YTCOON**  
Dongguan YTCOON Electronics Technology Co., Ltd

|          |            |             |                          |
|----------|------------|-------------|--------------------------|
| DRAWING  | DEV1       | TITLE:      | PHONE JACK CONNECTOR 压接式 |
| APPROVED |            | P/N:        | PJ15-06AB07-00           |
| DATE     | 2012.09.28 | DRAWING NO. | C-PJ15-00                |

|                   |             |
|-------------------|-------------|
| GENERAL TOLERANCE | X: ±0.20    |
|                   | .XX: ±0.15  |
|                   | .XXX: ±0.10 |
| ANGEL TOLERANCE   | X: ±3°      |
|                   | .XX: ±2°    |
|                   | .XXX: ±1°   |

|      |    |       |     |      |    |       |        |     |   |
|------|----|-------|-----|------|----|-------|--------|-----|---|
| UNIT | mm | SCALE | 1:1 | SIZE | A4 | SHEET | 1 of 1 | REV | A |
|------|----|-------|-----|------|----|-------|--------|-----|---|