



REV	ECN #	DESCRIPTION	DRAWING	APPROVED	DATE
A		NEW RELEASE	DEYI		04/26/12

- NOTES:
- 1.0 RATING:
 - 1.1 VOLTAGE:12 VAC (rms)
 - 1.2 CURRENT: 1 AMPERES MAX. PER CONTACT
 - 1.3 OPERATION TEMPERATURE RANGE: -25°C~+70°C
 - 2.0 ELECTRIC CHARACTERISTIC:
 - 2.1 CONTACT RESISTANCE:60mΩ MAX.
 - 2.2 INSULATION RESISTANCE:1909MΩ.
 - 2.3 DIELECTRIC WITHSTANDING VOLTAGE:500V AC FOR 1 MINUTE
 - 3.0 OPERATION LIFE: 5000 CYCLES
 - 4.0 MATERIAL/FINISH:SEE TABLE
 - 5.0 CONTACT PIN ASSIGNMENT:SEE TABLE

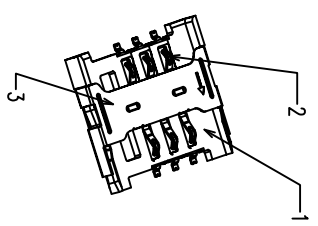
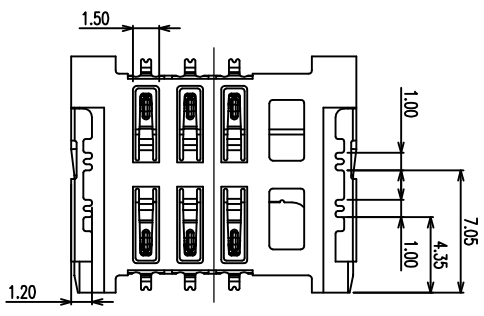
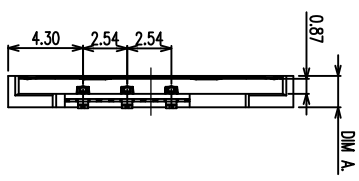
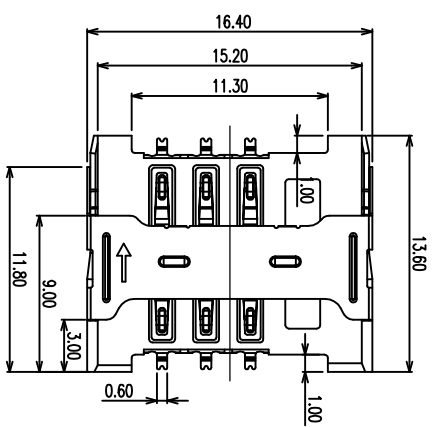
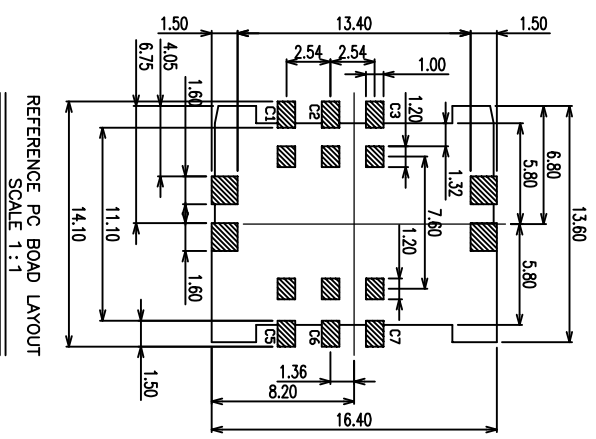

TABLE A:

ITEM	P/N	DIM.A	REMARK
1	SM07-06AB05-00	1.80	
2	SM07-06AB05-01	2.00	
3	SM07-06AB05-02	2.20	



- 料号编码
SM07-06 A B 05-XX
① ② ③ ④ ⑤
- ① 产品系列:
SM07: SIM卡连接器
② 产品PIN数:
06: 6PIN
③ 塑胶材料:
A: LCP
④ 塑胶颜色:
B: 黑色
⑤ 产品流水号
- 00: SIM CARD 1.8H 抽屜式
01: SIM CARD 2.0H 抽屜式
02: SIM CARD 2.2H 抽屜式
05: SIM CARD 1.5H 抽屜式

ITEM	NAME	Q'TY/EACH	MATERIAL/FINISHED	REMARK
3	shell	1	SUS304, STAINLESS STEEL	
2	contact	6	C5210, Copper Alloy, T=0.15mm Au Plated	
1	housing	1	LCP, THERMOPLASTIC UL94V-0 BLACK	

YTCOON
Dongguan YTCOON
Electronics Technology Co., Ltd

CUSTOMER DRAWING		DRAWING DEYI		TITLE: SIM CARD抽屜式	
GENERAL TOLERANCE		APPROVED		P/N: SM07-06AB05-XX	
X	±0.20	DATE: 2012.04.26		DRAWING NO. C-SM07-00	
.XX	±0.15				
.XXX	±0.10				
ANGEL TOLERANCE		UNIT	mm	SCALE	1:1
X	±3°	UNIT	mm	SCALE	1:1
.XX	±2°	UNIT	mm	SCALE	1:1
.XXX	±1°	UNIT	mm	SCALE	1:1

1 2 3 4 5 6 7 8 9 10
A B C D E F G
1 2 3 4 5 6 7 8 9 10