

REV	EON #	DESCRIPTION	DRAWING	APPROVED	DATE
A		NEW RELEASE	DEY1		2012.06.28

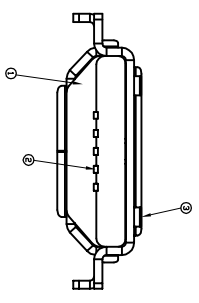
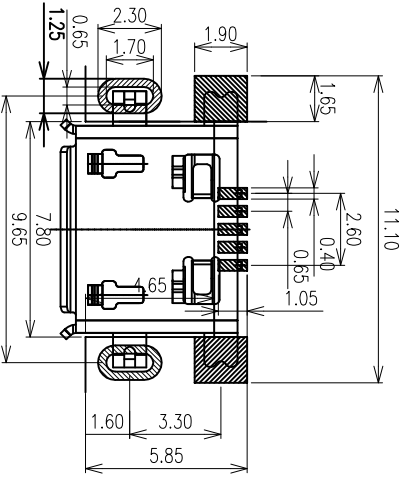
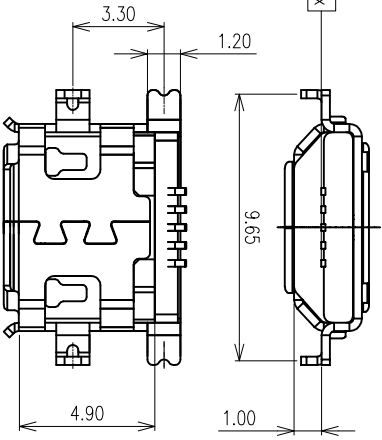
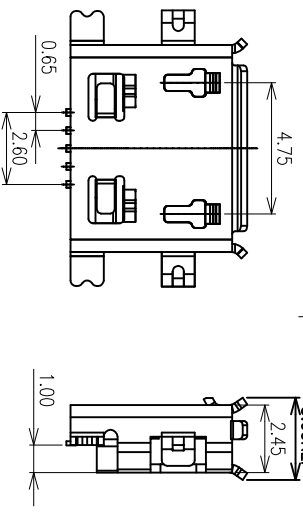
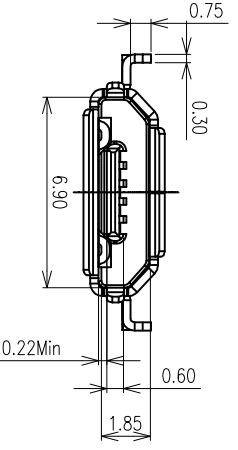

NOTES:

- MATERIAL:
  - HOUSING: THERMOPLASTIC FLAMMABILITY RATING UL94V-0
  - CONTACT: COPPERY ALLOY T=0.15mm
  - SHELL: STAINLESS STEEL T=0.30mm
- FINISH:
  - CONTACT:
    - Min. PLATED ON CONTACT AREA
    - F/F PLATING ON SOLDER TAIL AREA
    - 50~80μ" NICKEL UNDERPLATING OVERALL
  - SHELL:
    - 80~120 μ" W/ATER TIN PLATING ALL
    - 50~80μ" NICKEL UNDERPLATING OVERALL
- SPECIFICATION:
  - CURRENT RATING: 0.5A(2.5CONTACT)/1.8A(1.5CONTACT) MAX.
  - VOLTAGE: 30 VAC
  - TEMPERATURE RANGE: -30 °C ~ 85 °C
  - CONTACT RESISTANCE: 30 MILLIONHM MAX.
  - DIELECTRIC WITHSTANDING VOLTAGE: 250 VAC r.m.s
  - INSULATION RESISTANCE: 100 MEGOHMS MIN

RECOMMENDED PCB LAYOUT(TOP VIEW)  
GENERAL TOLERANCES:±0.05

PRODUCT NO.

MU08 - 05 A B 03 - 01

- ① 产品系列:
- ② 产品PIN数:
- ③ 材质:
- ④ 产品流水码:

05: SPIN  
A: LCP  
01: 外壳前贴后贴, 沉板1.0mm

NO.	DESCRIPTION	MATERIAL	REMARKS	QTY
3	SHELL	STAINLESS STEEL T=0.30mm	TIN/NI Plated	1PCS
2	CONTACT	COPPER ALLOY T=0.15mm	Au/NI Plated	1SET
1	HOUSING	Pb&T UL94V-0	BLACK	1PCS

**YTCOONN**  
Dongguan YTCOONN  
Electronics Technology Co., Ltd

CUSTOMER DRAWING

DRAWING DEY1

TITLE: MICRO USB SP 沉板1.0 前贴后贴, 有翻边

GENERAL TOLERANCE

X ±0.20  
XX ±0.15  
XXX ±0.10

APPROVED

P/N: MU08-05AB03-01

ANGEL TOLERANCE

X ±.3°  
XX ±2°  
XXX ±1°

DATE 2014.05.13

DRAWING NO. C-MU08-01

UNIT	SCALE	SIZE	A4	SHEET	1of1	REV	A
mm	1:1	A4					

